

# POOL FENCE

## AN INVESTMENT WORTH MAKING ...

### AND A REQUIREMENT OF THE CODE !

**Swimming pools, spas, and hot tubs are becoming more frequent in the back yards of homes across the State. While very enjoyable to the users, these places of comfort are very alluring to young children. Protection against unsupervised children is paramount in avoiding a household disaster.**



Barriers like pool fences are working! In 1985, New York State started requiring pool fences when the rate of child deaths (newborn to 4 years old) soared to 17 drownings per million. By 1999, that number dropped by 95%.

#### **When do I need a barrier?**

Barriers, such as fences, are required around swimming pools, hot tubs and spas. This includes both fixed and portable units, including pre-formed or inflatable pools. The only exception is when a swimming pool is not able to contain more than 24" of water.

#### **Are existing swimming pools exempt from barrier requirements?**

No. All swimming pools, no matter how old, are required to have a barrier around them. The Property Maintenance Code of New York State requires an approved barrier around all swimming pools, regardless of their age.

#### **What are the requirements for barriers?**

The *Residential Code of New York State* and the *Building Code of New York State* regulate the construction parameters of barriers. Several options are available.

1. A 48" barrier shall surround the pool area. The barrier can be made using various methods including masonry, wood, or metal. Whatever method is used, it must not allow passage of children through the barrier as well as be constructed to prevent climbing.
2. For above ground pools, the side wall can be used as part of the barrier as long as the walls are 48" above the ground and the access ladder is secured. A barrier can be placed on top of the pool if it doesn't quite make the 48" by itself.
3. When the wall of a building serves as the barrier, or a portion thereof, a power operated top can be used or alarms can be placed on the doors leading to the pool area.

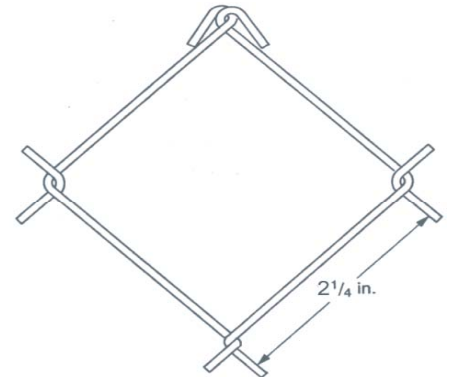

#### **Do I need to put a barrier up to protect my hot tub or spa?**

No. Hot tubs and spas are exempt from the barrier if equipped with a safety cover complying with the ASTM F1346 safety standard.

#### **Do fences, gates and folding ladders need to be locked?**

Yes. Pool gates and folding ladders do need to be locked when unsupervised. This needs to be achieved by a key, combination, or child-proof lock.

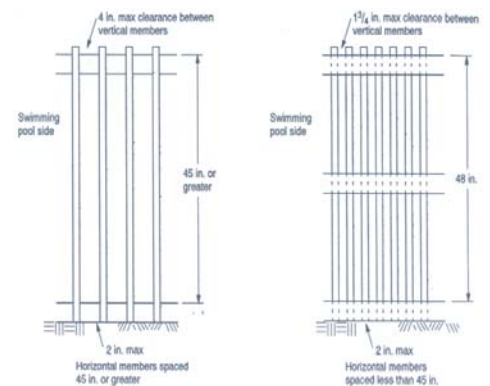

For more information, contact the Department of State Division of Code Enforcement and Administration 41 State St. Albany, NY 12231  
Phone: (518)-474-4073  
Fax: (518)-486-4487  
<http://www.dos.state.ny.us>



Specifics on fence construction and permitted gates are found in the *Residential Code of New York State* and the *Building Code of New York State*

